

PROCESS HEATING APPLICATION EXAMPLES

EXAMPLE 1: HEATING LIQUID IN A TANK

Description: An open steel tank, 3 ft. wide, 4 ft. long, 3 ft. deep and weighing 350lb., is filled with water to within 9 inches of the top. Bottom and sides have 4 inches of insulation. Water is to be heated from 50°F to 175°F within 1 hour and, from then on, approximately 12 gallons per hour will be drawn off and replaced.

Calculation of wattage required:

Considerations:

Beginning to final temperature: 50-175°F

Time available for Process Start-Up: 1 hour

Process cycle period: 1 hour

Weight and thermal properties of all materials:

Specific heat of steel: 0.12 Btu/lb./°F

Specific heat of water: 1.0 Btu/lb./°F

Density of water: 62.5 lb./cu.ft. or 8.3 lb./gal.

Weight of water in tank: (3 x 4 x 2.25) cu.ft.

x 62.5 lb./cu.ft. = 1688 lb.

Weight of additional water added during process:

12 gal./hr. x 8.34 lb./gal. = 100 lb.

Weight of tank: 350 lb.

Exposed surface areas and heat losses:

Amount of insulation: 4"

Water surface area: 12 sq.ft.

Tank vertical surface area: 42 sq.ft.

Tank bottom surface area: 12 sq.ft.

From graph 4T, heat losses from the water surface: At

175°F—750 watts/sq.ft.

From graph 1T, heat losses from the insulated surfaces:

At 175°F—8 watts/sq.ft. (bottom surface — 4 watts/sq.ft.)

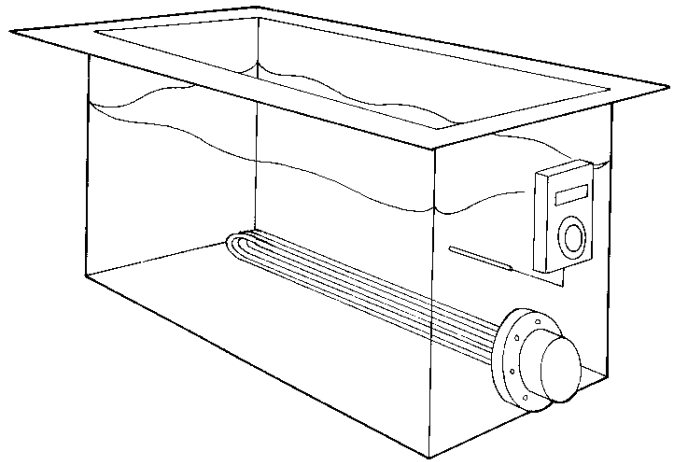

STEP 1: Wattage Required for Process Start-Up

$$Q_{ha} + Q_{ls} + CF = \text{kwh}$$

$$\text{kwh} = \text{kw}$$

Hours allowed for process start-up

A. Q_{ha}

$$\frac{350\text{lb.} \times 0.12 \text{ Btu/lb./}^\circ\text{F} \times (175-50)^\circ\text{F}}{3412 \text{ Btu/kwh}} = 1.54\text{kwh}$$

+

$$\frac{1688 \text{ lb.} \times 1.0 \text{ Btu/lb./}^\circ\text{F} \times (175-50)^\circ\text{F}}{3412 \text{ Btu/kwh}} = 61.84\text{kwh}$$

+

$$\text{Heat of fusion or vaporization} = \text{NONE}$$

$$= \underline{63.38\text{kwh}}$$

B. Q_{ls}

$$\frac{12 \text{ sq.ft.} \times 750 \text{ w/sq. ft.} \times 1 \text{ hr.}}{1000 \text{ w/kw}} \times \frac{1}{2} = 4.5\text{kwh}$$

+

$$\frac{42 \text{ sq.ft.} \times 8 \text{ w/sq. ft.} \times 1 \text{ hr.}}{1000 \text{ w/kw}} \times \frac{1}{2} = 0.17\text{kwh}$$

+

$$\frac{12 \text{ sq.ft.} \times 4 \text{ w/sq. ft.} \times 1 \text{ hr.}}{1000 \text{ w/kw}} \times \frac{1}{2} = 0.02\text{kwh}$$

$$= \underline{4.69\text{kwh}}$$

$$\text{C. CF} \quad 20\% (63.38 + 4.69) = \underline{13.61\text{kwh}}$$

Wattage Required for Process Start-up:

$$\frac{63.38 + 4.69 + 13.61}{1 \text{ hour}} = \underline{81.68\text{kwh}}$$

STEP 2: Wattage Required for Process Operation

$$Q_{ha2} + Q_{ls2} + CF = \text{kw}$$

D. Q_{ha2}

$$\frac{100 \text{ lb.} \times 1.0 \text{ Btu/lb./}^\circ\text{F} \times (175-50)^\circ\text{F}}{3412 \text{ Btu/kwh}} = 3.66\text{kwh}$$

$$\text{Heat of fusion or vaporization} = \text{NONE}$$

$$= \underline{3.66\text{kwh}}$$

E. Q_{ls2}

$$\frac{12 \text{ sq.ft.} \times 750 \text{ w/sq.ft.}}{1000 \text{ w/kw}} = 9.0\text{kwh}$$

+

$$\frac{42 \text{ sq.ft.} \times 8 \text{ w/sq.ft.}}{1000 \text{ w/kw}} = 0.34\text{kwh}$$

+

$$\frac{12 \text{ sq.ft.} \times 4 \text{ w/sq.ft.}}{1000 \text{ w/kw}} = 0.05\text{kwh}$$

$$= \underline{9.39\text{kwh}}$$

$$\text{F. CF} \quad 20\% (3.66 + 9.39) = \underline{2.61\text{kwh}}$$

Wattage Required for Process Operation:

$$3.66 + 9.39 + 2.61 = \underline{15.66\text{kw}}$$

In this application, with a significant difference between the wattage necessary for start-up versus operation, it is recommended to lengthen the time to initially bring the process to the required temperature. By allowing 7 hours for initial heat-up, the wattage required would drop to 18.36 kw. The time variable in Q_{ls} would be changed to 7 hrs. and the averaging figure to 2/3. However, during start-up, by placing a cover with 4" insulation over the top

surface, 16 kw would bring the process to temperature in less than 4 hours.

It is necessary to know the condition of the water. If the water is reasonably clean, a copper sheath immersion heater would be adequate, because corrosion of the elements would not be a consideration. As heat is transferred well from the element in the direct immersion heating of water, a watt density up to 60 watts per square inch would be acceptable. If any doubt exists about the process conditions, more research would be necessary.

As this process would not seem to require accurate temperature control, a D1 thermostat would most likely be adequate. Accuracy improvement would be accomplished with electronic controls such as the ETR-404. Careful design of the thermal system would lead to satisfactory process results.

EXAMPLE 2: CHANGING THE STATE OF A MATERIAL

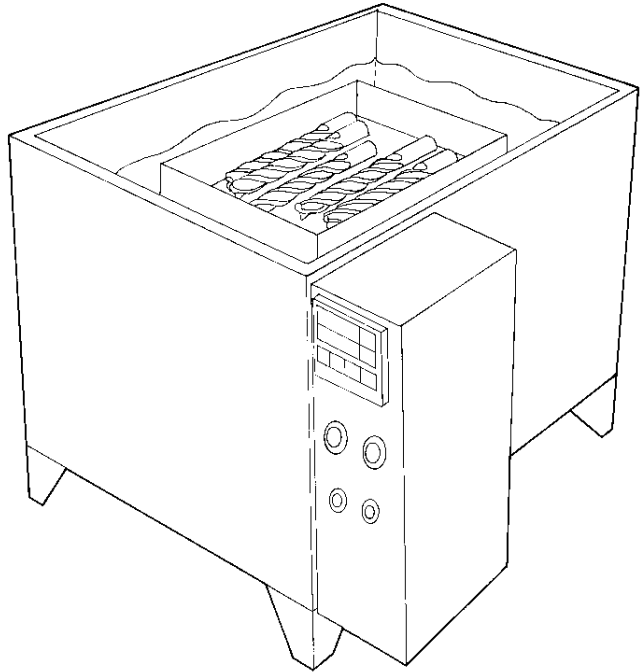

Description: An open, uninsulated tank, 1½ ft. wide, 2 ft. long, 1½ ft. deep and weighing 140 lbs., will contain 168 lbs. of paraffin. The manufacturer of steel drills must apply a coating of paraffin as protection prior to shipping. The paraffin needs to be heated from 70–150°F in 3 hours. The steel drills, each weighing .157 lb., are to be placed in a 5 lb. rack and dipped in the melted paraffin. 100 drills will be processed each cycle, 1500 per hour. Each cycle is 4 minutes. 20 additional pounds of paraffin will be required each hour.

Calculation of wattage required:

Considerations:

Beginning to final temperature: 70–150°F
Time available for process start-up: 3 hours
Process cycle period: 1 hour

Weight and thermal properties of all materials:

Specific heat of steel: 0.12 Btu/lb./°F

Specific heat of solid paraffin:

0.70 Btu/lb./°F

Melting point of paraffin: 133°F

Heat of fusion of paraffin: 63 Btu/lb.

Specific heat of melted paraffin:

0.71 Btu/lb./°F

Weight of tank: 140 lbs

Weight of rack: 5 lbs. each (75 lbs. total for 15 cycles/hour)

Weight of drills: .157 lb. each—1500/hr. (235.5 lbs. total/hr.)

Weight of paraffin: 168 lbs.

Weight of paraffin added during process: 20 lbs.

Exposed surface areas and heat losses:

Amount of insulation: none

Paraffin surface area: 3 sq. ft.

Tank vertical surface area: 10.5 sq. ft.

Tank bottom surface area: 3 sq. ft.

From graph 3T, heat losses from paraffin surface:

At 150°F—70 watts/sq. ft.

From graph 1T, heat losses from uninsulated tank

surface: At 150°F—55 watts/sq. ft.

(bottom surface—27 watts/sq.ft.)

STEP 1: Wattage Required for Process Start-Up

$$\frac{Q_{ha} + Q_{ls} + CF}{\text{Hours allowed for process start-up}} = \text{kwh}$$

A. Q_{ha}

To heat tank:
 $\frac{140 \text{ lb.} \times 0.12 \text{ Btu/lb./}^\circ\text{F} \times (150-70)^\circ\text{F}}{3412 \text{ Btu/kwh}} = 0.39\text{kwh}$

To heat solid paraffin:
 $\frac{168 \text{ lb.} \times 0.70 \text{ Btu/lb./}^\circ\text{F} \times (133-70)^\circ\text{F}}{3412 \text{ Btu/kwh}} = 2.17\text{kwh}$

To heat melted paraffin:
 $\frac{168 \text{ lb.} \times 0.71 \text{ Btu/lb./}^\circ\text{F} \times (150-133)^\circ\text{F}}{3412 \text{ Btu/kwh}} = 0.59\text{kwh}$

Heat of fusion to melt paraffin:
 $\frac{168 \text{ lb.} \times 63 \text{ Btu/lb.}}{3412 \text{ Btu/kwh}} = 3.10\text{kwh}$

6.25kwh

B. Q_{ls}

Average loss from paraffin surface:
 $\frac{3 \text{ sq.ft.} \times 70 \text{ w/sq.ft.} \times 3 \text{ hrs.} \times \frac{1}{3}}{1000 \text{ w/kw}} = 0.42\text{kwh}$

Average loss from tank vertical surface:
 $\frac{10.5 \text{ sq.ft.} \times 55 \text{ w/sq.ft.} \times 3 \text{ hrs.} \times \frac{1}{3}}{1000 \text{ w/kw}} = 1.16\text{kwh}$

Average loss from tank bottom surface:
 $\frac{3 \text{ sq.ft.} \times 27 \text{ w/sq.ft.} \times 3 \text{ hrs.} \times \frac{1}{3}}{1000 \text{ w/kw}} = 0.16\text{kwh}$

1.74kwh

C. CF

20% (6.25 + 1.74) = 1.60kwh

Wattage Required for Process Start-Up:

$\frac{6.25 + 1.74 + 1.60}{3 \text{ hours}} = \underline{\underline{3.20\text{kw}}}$

STEP 2: Wattage Required for Process Operation

$$Q_{ha2} + Q_{ls2} + CF = \text{kw}$$

D. Q_{ha2}

To heat drills and racks:
 $\frac{(235.5 + 75) \text{ lbs.} \times 0.12 \text{ Btu/lb./}^\circ\text{F} \times (150-70)^\circ\text{F}}{3412 \text{ Btu/kwh}} = 0.87\text{kwh}$

To heat solid paraffin added during process:
 $\frac{20 \text{ lbs.} \times 0.70 \text{ Btu/lb./}^\circ\text{F} \times (133-70)^\circ\text{F}}{3412 \text{ Btu/kwh}} = 0.26\text{kwh}$

To heat melted paraffin added during process:
 $\frac{20 \text{ lbs.} \times 0.71 \text{ Btu/lb./}^\circ\text{F} \times (150-133)^\circ\text{F}}{3412 \text{ Btu/kwh}} = 0.07\text{kwh}$

Heat of fusion to melt additional paraffin:
 $\frac{20 \text{ lbs.} \times 63 \text{ Btu/lb.}}{3412 \text{ Btu/kwh}} = 0.37\text{kwh}$

1.57kwh

E. Q_{ls2}

Loss from paraffin surface:
 $\frac{3 \text{ sq.ft.} \times 70 \text{ w/sq.ft.}}{1000 \text{ w/kw}} = 0.21\text{kwh}$

Loss from tank vertical surface:
 $\frac{10.5 \text{ sq.ft.} \times 55 \text{ w/sq.ft.}}{1000 \text{ w/kw}} = 0.58\text{kwh}$

Loss from tank bottom surface:
 $\frac{3 \text{ sq.ft.} \times 27 \text{ w/sq.ft.}}{1000 \text{ w/kw}} = 0.08\text{kwh}$

0.87kwh

G. CF

20%(1.57 + 0.87) = 0.49kwh

Wattage Required for Process Operation:

1.57 + .87 + .49 = 2.93kw

The results of this particular example were that the start-up and operating wattage requirement were nearly identical. 3.2 kw will be the power installed. As can be seen from 23T, the watt density cannot exceed 16 watts/sq.in. in heating paraffin. As immersion heating is not reasonable, the best heat source would be HD Strip Heaters mounted on the tank bottom. This will provide efficient conductive and convective heat transfer. Accurate temperature control is required as the process is near to the maximum operating temperature of this material, 150°F, which is also found on 23T. A PID control such as an ETR-9090 would be the best selection. The placement of the thermal system components as described will lead to satisfactory process results.

EXAMPLE 3: SURFACE HEATING

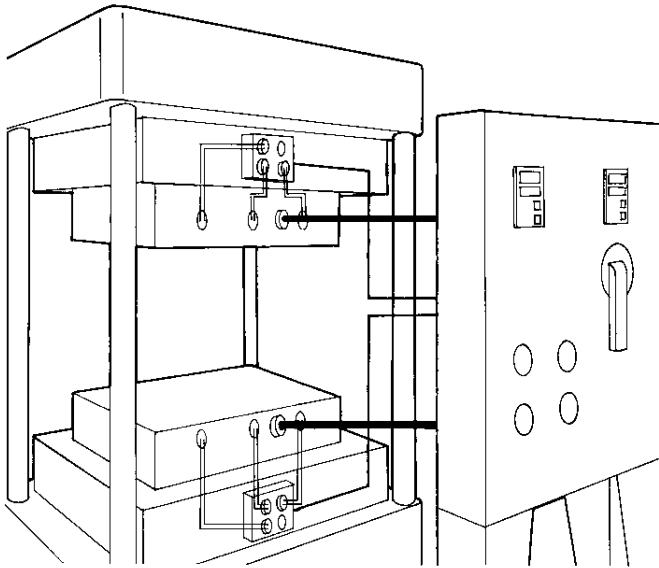

Description: A press has two steel platens, each 3ft. X 8ft. X 3" thick. After initial heat-up from 70°F to 350°F in 2 hours, 60 lb. sheets of fiberboard are processed by drying and compressing to ¼ inch thickness at a rate of 3 per hour. Platens are closed during initial heat-up and open for 2 minutes of the 20 minute working cycle. The horizontal non-working surfaces of the platens are insulated from the press, but the edges are exposed.

Calculation of wattage required:

Considerations:

Beginning to final temperature: 70–350 °F

Time available for process start-up: 2 hours

Process cycle period: 20 minutes each sheet

3 sheets per hour

Weight and thermal properties of all materials:

Specific heat of steel: 0.12 Btu/lb./°F

Specific heat of fiberboard: 0.65 Btu/lb./°F

Density of steel: 491 lb./cu.ft.

Weight of platens: 2(3X8X.25) cu.ft. X 491lb./cu.ft.
= 5892 lb.

Weight of fiberboard: 60 lbs. each sheet
180 lbs. per hour

Exposed surface areas and heat losses:

Amount of insulation:

No insulation on sides

Negligible losses from insulated horizontal surfaces

Exposed platen side area: 11 sq.ft.

Exposed platen open area: 48 sq.ft.

From graph 1T, heat losses from uninsulated metal surfaces:

At 350°F—275 watts/sq. ft.

STEP 1: Wattage Required for Process Start-Up

$$Q_{ha} + Q_{ls} + CF = \text{kwh}$$

$$\frac{\text{kwh}}{\text{Hours allowed for process start-up}} = \text{kw}$$

A. Q_{ha}

$$\frac{5892 \text{ lb.} \times 0.12 \text{ Btu/lb./}^\circ\text{F} \times (350-70)^\circ\text{F}}{3412 \text{ Btu/kwh}} = 58.02\text{kwh}$$

+

$$\text{Heat of fusion or vaporization:} = \text{None}$$

$$= \underline{58.02\text{kwh}}$$

B. Q_{ls}

Average loss from uninsulated side areas:

$$\frac{11 \text{ sq. ft.} \times 275 \text{ w/sq.ft.} \times 2 \text{ hr.}}{1000 \text{ w/kw}} \times \frac{1}{2} = 3.02\text{kwh}$$

$$= \underline{3.02\text{kwh}}$$

C. CF

$$20\%(58.02 + 3.02) = \underline{12.21\text{kwh}}$$

Wattage Required for Process Start-Up:

$$\frac{58.02 + 3.02 + 12.21}{2 \text{ hours}} = \underline{36.62\text{kw}}$$

STEP 2: Wattage required for process operation

$$Q_{ha2} + Q_{ls2} + CF = \text{kw}$$

D. Q_{ha2}

To heat fiberboard:

$$\frac{60 \text{ lb.} \times 0.65 \text{ Btu/lb./}^\circ\text{F} \times (350-70)^\circ\text{F}}{3412 \text{ Btu/kwh}} = 3.20\text{kwh}$$

+

$$\text{Heat of fusion or vaporization:} = \text{None}$$

$$= \underline{3.20\text{kwh}}$$

E. Q_{ls2}

Loss from uninsulated side areas:

$$\frac{11 \text{ sq.ft.} \times 275 \text{ w/sq.ft.} \times 0.33 \text{ hr.}}{1000 \text{ w/kw}} = 1.00\text{kwh}$$

+

Loss from open platen:

$$\frac{48 \text{ sq.ft.} \times 275 \text{ w/sq.ft.} \times 0.33 \text{ hr.}}{1000 \text{ w/kw}} = 4.36\text{kwh}$$

$$= \underline{5.36\text{kwh}}$$

F. CF

$$20\%(3.20 + 5.36) = \underline{1.71\text{kwh}}$$

Wattage required for each 20 minute cycle:

$$3.20 + 5.36 + 1.71 = 10.27\text{kwh}$$

Wattage Required for Process Operation:

$$\frac{10.27 \text{ kw/cycle}}{.33 \text{ hr./cycle}} = \underline{31.12\text{kw}}$$

As the start-up and operating requirements are close, 36.62kw will be installed.

This system is a large thermal mass with control accuracy requirements at a minimum because of the non-critical temperatures of the process in relation to the product. HD Strip Heaters or tubular heaters in milled slots or cartridge or tubular heaters in drilled holes would be acceptable heat sources for this application. Both the top and bottom platens would be sensed and if greater accuracy was desired, each platen could be zoned.

EXAMPLE 4: PROCESS AIR HEATING

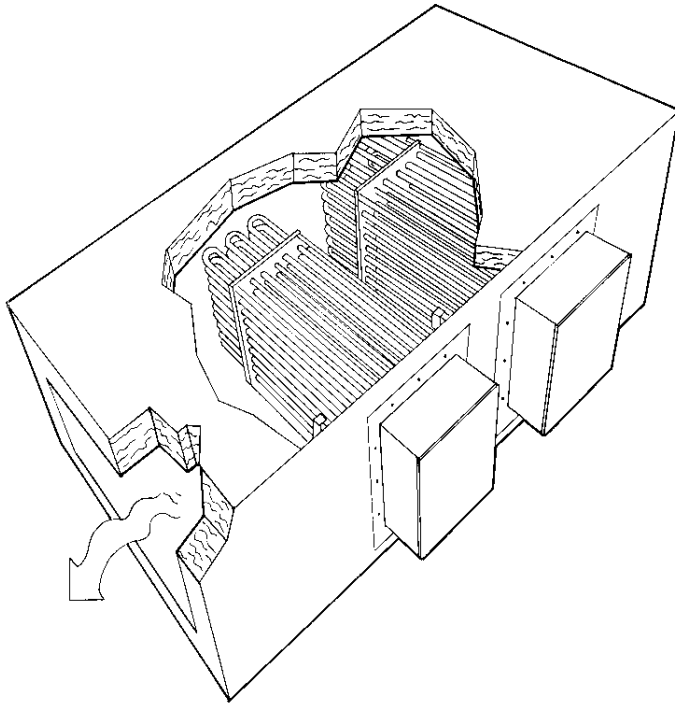

Description: A drying process requires 2500 cubic feet of air per minute at 275°F. Incoming air temperature has already been heated to 200°F along the way. The air will need to travel an additional 10 feet from the heater exhaust to the process. Dimensions of the duct are 24" wide x 24" high and is covered with 2" of insulation. There is no recirculation of the air. As this is a continuous process, start-up calculations are not required.

Calculation of wattage required:

Considerations:

Beginning to final temperature: 200–275°F
 Duct opening: 2 ft. x 2 ft.

Weight and thermal properties of all materials:

From 10T, average specific heat of air:
 specific heat at 200°F = 0.242 Btu/lb./°F
 specific heat at 275°F = 0.243 Btu/lb./°F

$$\text{Average} = \frac{.242 + .243}{2} = .2425 \text{ Btu/lb./}^\circ\text{F}$$

From 10T, density of air at 200°F: 0.060 lb./cu.ft.
 From 10T, density of air at 275°F: 0.054 lb./cu.ft.

Weight of air processed per hour:
 2500 cfm x 0.060 lb./cu.ft. x 60 min./hr. = 9000 lbs.

Exposed surface areas and heat losses:
 Amount of insulation: 2"
 Surface area of duct: 80 sq.ft.
 From graph 2T, heat losses from insulated surfaces at 275°F: 5 watts/sq.ft.

STEP 2: Wattage Required for Process Operation

$$\text{Qha2} + \text{Qls2} + \text{CF} = \text{kwh}$$

D. Qha2

$$\frac{9000 \text{ lbs.} \times 0.2425 \text{ Btu/lb./}^\circ\text{F} \times (275-200)^\circ\text{F}}{3412 \text{ Btu/kwh}} = 47.97\text{kwh}$$

$$= \underline{47.97\text{kwh}}$$

E. Qls2

$$\frac{\text{Losses from insulated duct surface: } 80 \text{ sq.ft.} \times 5 \text{ w/sq.ft.} \times 1 \text{ hr.}}{1000 \text{ w/kw}} = 0.40\text{kwh}$$

$$= \underline{0.40\text{kwh}}$$

F. CF

$$20\%(47.97 + 0.40) = \underline{9.67\text{kwh}}$$

Wattage Required for Process Operation:

$$47.97 + 0.40 + 9.67 = \underline{58.04\text{kwh}}$$

To select the appropriate heater as to the type and watt density, it is necessary to determine the outlet velocity. Each OGDEN Process Air Heater has maximum outlet air temperatures based upon the air velocity. Air and other gases' molecules move further apart as heating occurs, causing the density to decrease (become lighter) as the temperature increases. Because the area the gas passes through in a duct heater is constant, the velocity increases. It is important to note that the difference between the inlet velocity and density and the outlet velocity and density could be significant based upon the temperature differential of the two. See 50T. If air velocity versus outlet air temperature is not within catalog guidelines, element overheating and failure will occur.

To determine the Outlet Velocity:

$$\text{Outlet Velocity (fpm}_2\text{)} = \text{Inlet Velocity (fpm}_1\text{)} \times \frac{\text{Inlet Density}}{\text{Outlet Density}}$$

To determine the Inlet Velocity:

$$\text{Inlet Velocity (fpm}_1\text{)} = \frac{\text{cfm}}{\text{Duct Opening (sq. ft.)}}$$

From Example 4:

$$\text{Inlet Velocity (fpm}_1\text{)} = \frac{2500}{2 \times 2} = 625 \text{ fpm}$$

$$\text{Outlet Velocity (fpm}_2\text{)} = 625 \text{ fpm} \times \frac{2500 \text{ cfm} \times 0.060 \text{ lb./cu.ft.}}{2500 \text{ cfm} \times 0.054 \text{ lb./cu.ft.}}$$

$$= 625 \text{ fpm} \times \frac{150}{135}$$

$$= 694.4 \text{ fpm}$$

$$\text{fps} = \frac{695 \text{ fpm}}{60 \text{ sec/min}}$$

$$\text{fps} = 11.57$$

Based upon the requirement of 58.04 kw and that the outlet velocity versus the outlet temperature is well within the limitations of the ODH Process Air Heaters as shown in that catalog section, a proper selection would be the ODH-60. In further checking, a tubular heater at 22 watts per square inch operating in distributed air of 9 fps would be producing less than 1000°F sheath temperature per Chart 15T. As this process is over 11 fps, element temperature will never be a problem as long as this velocity exists. To be certain, a type K thermocouple will be attached to an element to provide input to a limit control. The process sensor should be mounted down-stream from the heater to be certain the temperature is 275°F at the process. An ETR Temperature Control will provide satisfactory process control.

EXAMPLE 5: OVEN HEATING

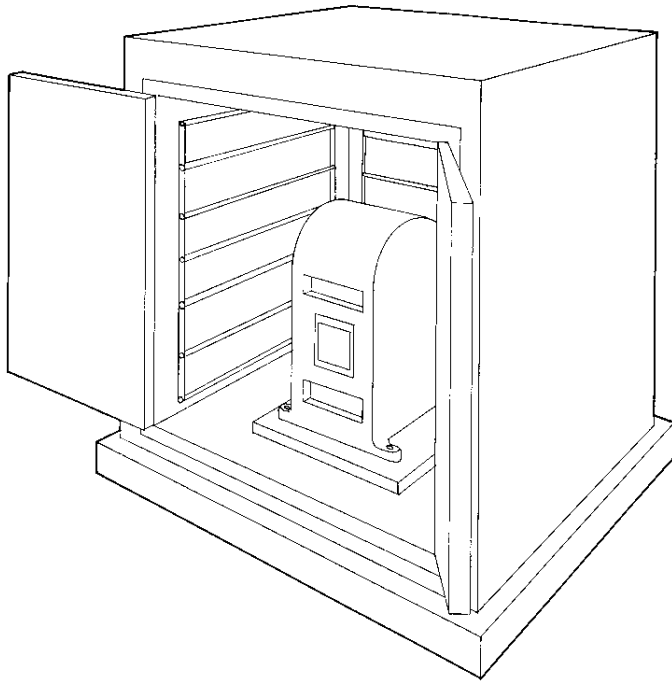

Description: An oven with inside dimensions of 4 ft. wide, 2 ft. deep and 2 ft. high, weighs 800 lbs., contains a 35 lb. steel tray and is covered with 2 inches of cerafelt insulation weighing 15.5 lbs. After being heated from 60 to 250°F in 1 hour, one 75 lb. motor will be dried every 15 minutes. After start-up, air is vented at the rate of 2 complete changes per cycle. It can be assumed that there are 2 lbs. of water in each motor.

Calculation of wattage required:

Considerations:

Beginning to final temperature: 60–250°F

Time available for process start-up: 1 hour

Process cycle period: 15 minutes each motor
4 motors per hour

Weight and thermal properties of all materials:

Specific heat of steel: 0.12 Btu/lb./°F

Weight of oven: 800 lbs.

Weight of motor: 75 lbs.

Weight of tray: 35 lbs.

Specific heat of cerafelt insulation: 0.25 Btu/lb./°F

Weight of cerafelt insulation: 15.5 lbs.

Specific heat of air: 0.237 Btu/lb./°F

Density of air: 0.08 lb./cu.ft.

Weight of air in oven (4 x 2 x 2) x 0.08 lb./cu. ft. = 1.28lb.

Specific heat of water: 1.0 Btu/lb./°F

Heat of vaporization of water: 965 Btu/lb.

Weight of water present each cycle: 2 lbs.

Exposed surface areas and heat losses:

Amount of insulation: 2"

Oven vertical and top surface area: 32 sq.ft.

Oven bottom surface area: 8 sq.ft.

From graph 2T, heat losses from the insulated

surfaces at 250°F: 8 watts/sq. ft. (Bottom surface = 4 watts/sq.ft.)

STEP 1: Wattage Required for Process Start-Up

$$\begin{array}{rcl} \text{Qha} + \text{Qls} + \text{CF} & = & \text{kwh} \\ \text{kwh} & = & \text{kw} \end{array}$$

Hours allowed for process start-up

A. Qha

$$\begin{array}{rcl} \text{To heat oven:} & & \\ \frac{800 \text{ lb.} \times 0.12 \text{ Btu/lb./}^\circ\text{F} \times (250-60)^\circ\text{F}}{3412 \text{ Btu/kwh}} & = & 5.34\text{kwh} \\ & + & \end{array}$$

$$\begin{array}{rcl} \text{To heat tray:} & & \\ \frac{35 \text{ lb.} \times 0.12 \text{ Btu/lb./}^\circ\text{F} \times (250-60)^\circ\text{F}}{3412 \text{ Btu/kwh}} & = & 0.23\text{kwh} \\ & + & \end{array}$$

$$\begin{array}{rcl} \text{To heat air:} & & \\ \frac{1.28 \text{ lb.} \times 0.237 \text{ Btu/lb./}^\circ\text{F} \times (250-60)^\circ\text{F}}{3412 \text{ Btu/kwh}} & = & 0.02\text{kwh} \\ & + & \end{array}$$

$$\begin{array}{rcl} \text{To heat insulation:} & & \\ \frac{15.5 \text{ lb.} \times 0.25 \text{ Btu/lb./}^\circ\text{F} \times (250-60)^\circ\text{F}}{3412 \text{ Btu/kwh}} & = & 0.22\text{kwh} \\ & + & \end{array}$$

$$\begin{array}{rcl} \text{Heat of fusion or vaporization:} & = & \text{None} \\ \hline & = & \underline{\underline{5.81\text{kwh}}} \end{array}$$

B. Qls

$$\begin{array}{rcl} \text{Average loss from insulated vertical and} & & \\ \text{top oven surfaces:} & & \\ \frac{32 \text{ sq.ft.} \times 8 \text{ w/sq.ft.} \times 1 \text{ hr.}}{1000 \text{ w/kw}} \times \frac{1}{2} & = & 0.13\text{kwh} \\ & + & \end{array}$$

$$\begin{array}{rcl} \text{Average loss from insulated bottom} & & \\ \text{oven surface:} & & \\ \frac{8 \text{ sq.ft.} \times 4 \text{ w/sq.ft.} \times 1 \text{ hr.}}{1000 \text{ w/kw}} \times \frac{1}{2} & = & 0.02\text{kwh} \\ \hline & = & \underline{\underline{0.15\text{kwh}}} \end{array}$$

C. CF

$$30\% (5.81 + 0.15) = \underline{\underline{1.79\text{kwh}}}$$

Wattage Required for Process Start-Up:

$$\frac{5.81 + .15 + 1.79}{1 \text{ hour}} = \underline{\underline{7.75\text{kw}}}$$

STEP 2: Wattage Required for Process Operation

$$\text{Qha2} + \text{Qls2} + \text{CF} = \text{kw}$$

D. Qha2

$$\begin{array}{rcl} \text{To heat motor:} & & \\ \frac{75 \text{ lb.} \times .12 \text{ Btu/lb./}^\circ\text{F} \times (250-60)^\circ\text{F}}{3412 \text{ Btu/kwh}} & = & 0.50\text{kwh} \\ & + & \end{array}$$

$$\begin{array}{rcl} \text{To heat air:} & & \\ \frac{(2)1.28 \text{ lb.} \times 0.237 \text{ Btu/lb./}^\circ\text{F} \times (250-60)^\circ\text{F}}{3412 \text{ Btu/kwh}} & = & 0.03\text{kwh} \\ & + & \end{array}$$

$$\begin{array}{rcl} \text{To heat water:} & & \\ \frac{2 \text{ lb.} \times 1 \text{ Btu/lb./}^\circ\text{F} \times (212-60)^\circ\text{F}}{3412 \text{ btu/kwh}} & = & 0.09\text{kwh} \\ & + & \end{array}$$

$$\begin{array}{rcl} \text{Heat of vaporization to evaporate water:} & & \\ \frac{2 \text{ lb.} \times 965 \text{ Btu/lb.}}{3412 \text{ Btu/kwh}} & = & 0.56\text{kwh} \end{array}$$

$$= \underline{\underline{1.18\text{kwh}}}$$

E. QIs2

Loss from insulated vertical and top oven surfaces:

$$\frac{32 \text{ sq.ft.} \times 8 \text{ w/sq.ft.} \times .25 \text{ hrs.}}{1000 \text{ w/kw}} = 0.06\text{kwh}$$

Loss from insulated bottom oven surface:

$$\frac{8 \text{ sq.ft.} \times 4 \text{ w/sq.ft.} \times .25 \text{ hrs.}}{1000 \text{ w/kw}} = 0.01\text{kwh}$$

$$= \underline{0.07\text{kwh}}$$

F. CF

30% (1.18 + 0.07) = 0.38kwh
 Wattage required for each 15 minute cycle:
 1.18 + 0.07 + 0.38 = 1.63kwh

Wattage Required for Process Operation:

$$\frac{1.63 \text{ kw/cycle}}{.25 \text{ hr./cycle}} = \underline{\underline{6.52\text{kw}}}$$

As can be seen, a 30% contingency factor was utilized in this process. Additional heat losses will likely occur as the oven doors are frequently opened. As the wattage requirement for the start-up is greater than the operating requirement, 7.75kw will be installed. The extra wattage can be considered an additional safety measure. Either tubular heaters or HD Strip Heaters mounted to the oven wall would be acceptable. A time proportioning ETR Temperature Control with an exposed junction type J thermocouple would provide the proper control.

DETERMINING WATT DENSITY

IMMERSION HEATERS:

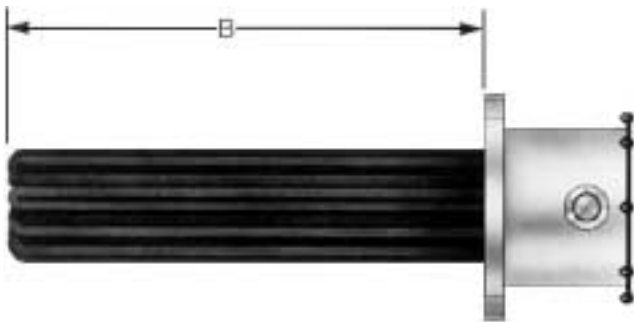

$$B \text{ dim.} = \frac{\text{EHL}}{\# \text{elements} \times 2} + \text{cold area}$$

$$\text{EHL} = (\# \text{ elements} \times 2 \times B) - (\text{cold area} \times \# \text{ elements} \times 2)$$

$$\text{EHL} = \frac{\text{Wattage}}{\text{element dia.} \times \text{w/sq.in.} \times \pi}$$

$$\text{Watt Density (w/sq.in.)} = \frac{\text{Wattage}}{\text{element dia.} \times \text{EHL} \times \pi}$$

To determine the watt density when kw and immersion depth (B dim.) are known:

Assume—25kw
 B = 30" (6 cold area)
 6" Flanged Immersion Heater—18 elements

Find—Watt density

$$\text{EHL} = (18 \times 2 \times 30) - (6 \times 18 \times 2)$$

$$\text{EHL} = 864"$$

$$\text{Watt density} = \frac{25000}{.475 \times 864 \times \pi}$$

$$\text{Watt density} = 19.4 \text{ w/sq.in.}$$

To determine immersion depth when kw and watt density limitations are known:

Assume—48kw
 22w/sq.in.
 8" Flanged Immersion Heater
 24 elements (6" cold area)

Find—B dimension

$$\text{EHL} = \frac{48000}{.475 \times 22 \times \pi}$$

$$\text{EHL} = 1463"$$

$$B = \frac{1463}{(24 \times 2)} + 6$$

$$B = 36\frac{1}{2}"$$

ESTIMATING SHEATH WATT DENSITY FOR OTHER PRODUCTS

BAND HEATERS:

$$\text{Watts/sq.in.} = \frac{\text{Wattage}}{(\text{dia} \times \pi \times \text{width}) - \text{width}}$$

See respective catalog section for each band heater for accurate watt density formulas.

CARTRIDGE AND TUBULAR HEATERS:

$$\text{Watts/sq.in.} = \frac{\text{Wattage}}{\text{dia.} \times \text{heated length} \times \pi}$$

MICA STRIP HEATERS:

$$\text{Watts/sq.in.} = \frac{\text{Wattage}}{(\text{heated length} \times \text{width}) - \text{width}}$$

HD STRIP HEATERS:

$$\text{Watts/sq.in.} = \frac{\text{Wattage}}{\text{heated length} \times 3.75}$$

CHANNEL HEATERS:

$$\text{Watts/sq.in.} = \frac{\text{Wattage}}{\text{heated length} \times 3.625}$$